



NEWSLETTER



Editor : Bob Young
December 2007

SUBSCRIPTIONS FOR 2008 MEMBERSHIP

(Including a £10 Gift Voucher for BMFA 'A' and 'B' Certificate holders)

The membership subscription for 2008 will be £55 (Juniors £27), reduced by £5 and £3 from last year. BMFA membership has been set at £28 for adults and £15 for juniors. So when you come to the **Annual General Meeting on Thursday evening, 6th December at the Battle of Britain Club, please bring a cheque** drawn in favour of West London MAC, or the **exact amount in cash (ie £55 or £83)**, to speed the collection process. There will be food and drink on the house as usual. The Committee wants to encourage all members to achieve BMFA 'A' or 'B' Certificate standard and as an incentive, all renewing members providing evidence of BMFA certification when renewing their WLMAC membership will receive a £10 gift voucher redeemable at Brentford RC Centre against purchases of £75 or more. We already hold that evidence if you renewed your BMFA membership through WLMAC last year but those of you who joined BMFA privately or through another club should bring your BMFA membership cards as evidence of your 'A' or 'B' certification.

Those intending to renew their membership but unable to attend the AGM should send their cheques payable to West London MAC to our Treasurer Peter Nielsen at 176 Cherry Tree Rd, Beaconsfield, HP9 1BA. Tel: 01494675716.



QUOTATIONS - FORESIGHT ON FLIGHT

The time will come when thou shalt lift thine eyes to watch a long drawn battle in the skies England shall reign sovereign of the conquered air - part of a poem by Gray in 1737.

Against an army sailing through the clouds neither walls, nor mountains, nor seas, could afford any security - Samuel Johnson in 1759.

Aerial navigation...will soon be brought home to man's convenience - Sir George Cayley in 1809.

I suppose that we will soon travel by air vessel—Lord Byron

The day that Bleriot flew the channel (1909) marked the time when Britain must seek another form of defence beside its ships - Sir Alan Cobham.

We do not consider that aeroplanes will be of any possible use for war purposes - British Secretary of State for War in 1910.

The Rolls Royce Board passed a resolution in 1913 declaring that they would never make aero engines. Henry Royce immediately set about the design of one - the Eagle - Lord Hives.
Leon Taylor



THE GLOBAL HAWK as spotted by Lew Wrapson



Another summer picture of Mike Sullivan's Chipmunk



The Brentford RC's Christmas Bazaar was very popular with many of their LED light systems sold. Club members took the opportunity to stock up on other modelling gear.

SECRETS OF THE ROTATING CYLINDER VALVE

The RCV engine was conceived by Keith Lawes, who machined three prototypes himself before joining forces with Eric Hill to set up RCV Engines to commercialise the technology, mainly through licensing agreements.

The engine's cylinder rotates around a piston at half crankshaft speed. A single port in the rotating cylinder passes fixed radial inlet and exhaust ports to provide the valve function. The cylinder is combined with the rotary valve in a single component - hence the name rotating cylinder valve.

"It's a relatively simple engine design," says Brian Mason, a director of RCV. "Basically it has a crankshaft and a piston the same as any other reciprocating piston engine. But the cylinder is geared to the crankshaft and it rotates at half the crank speed. So it's a four-cycle engine and in the top of the cylinder there's an opening which is the port and combustion chamber. As that indexes round it exposes the intake port, the spark or globe plug, and exhaust. It's got very few moving components."

An important aspect of the design is that the power output can be taken from the crankshaft or from the cylinder itself, offering variations in torque and speed.

The engine is the result of several years' work. "We've patented it fairly comfortably," says Hill. "Initially the patenting process was based on the fact that we take the power out of the cylinder, which was unusual. After that it was because we were applying different features to an engine which took the power from the rotor. Then we were able to build up other aspects like thermo issues, different valve arrangements, all working on a rotary valve cylinder

engine. It now has a layer of patents, and we have design copyright too - which is important when you are operating in places like China."

RCV now comprises a small, experienced engineering team which carries out engine prototype work, design and development, and a small amount of manufacture. The firm does a lot of its own machining and small-engine testing at its dyno facility. The team uses the Pro-Engineer CAD system for 3D design, while engine performance simulation is carried out using Ricardo code. The firm looks to license its technology rather than manufacture, although UAV engine production might be a special case because of the high standards and small batches involved.

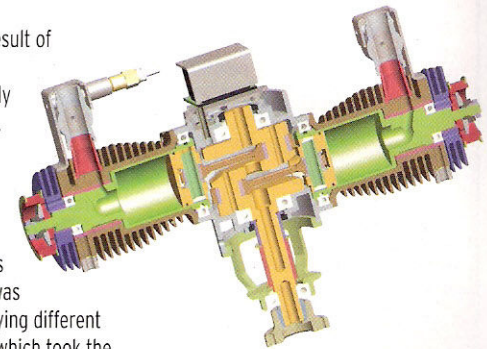
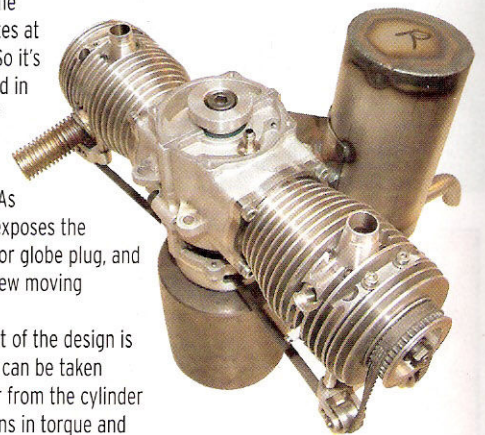

Few moving parts: The first engine built for Honeywell's UAV following development testing (top). Cutaway of the engine (bottom)

DIARY DATES FOR 2008

14th Feb 2008	BofBC 2008 Projects
13th Mar 2008	BofBC TBA
10th Apr 2008	BofBC TBA
8th May 2008	BofBC Bring and Buy
11th June 2008	Field Meeting Electric
6th July 2008	Field Scale day

