



Washout August

Well, if it wasn't rain in August it was high winds that caused a poor summer for West London modellers. Admittedly, the heading photo shows one of the few good days for flying but there weren't that many, now billed as the wettest August ever. The grass stayed green at least.



We held a BBQ at the field on 7th August and invited Watford Wayfarers to attend, the weather was ok but it was a rather grey evening as the snap above shows.

All went well except I put my Oxalys into the ground, disorientation and dumb thumbs being the reason. I managed to get confused about its orientation and I was too close to the 'No Fly Line'. In the second or two it took me to ensure that I didn't cross the line, it was all too late. This was an excellent plane and flew nicely, a shame about the Pilot! There is only one way to deal with the bits left over after all the best bits have been stripped out!

John Fowles lost his Wot 4 and Gun Jason had a mid air with his foamy Delta, Watford members must have thought that we were a lost cause.



Sarik Vacform had a lovely little 3D printer on display. It was making little models, this one is a small Castle, similar to a Chess piece. The astonishing thing is that the Castle is hollow and complete with a spiral staircase inside, just visible through the window. Now I know that the printer needs a computer programme to print but the printer was on sale for £300, it was a build it yourself from a kit version. This printer can print things about 4" across and 6" high, its not quick but it was quiet so you could leave it printing overnight. Interestingly, the printer had 3D printed parts in its own construction.



I can see a time where for example, you want some scale exhausts for your Mustang, you'll buy the programme that allows you to print your own. You'll pay and then download the programme, change the scale to match whatever size exhausts you want and then print them. Similarly, if you need a pilot, you buy the programme with the correct stye of pilot and print it yourself at whatever scale you wish. This printer pictured is very similar to the one on offer.

Tony The Tree Climber

On 1st August Peter Dorrow managed to get his Yak stuck up a tree and whilst we could see it, there was no way we'd be able to reach it. So Peter rang the telephone number for the tree climber that's displayed in the Club Hut. As luck would have it, both Father and son were free and arrived inside 15 minutes. So off went the rescue party, they retrieved the model which was only lightly damaged. The Tree climber, Tony, was very good indeed, his rescue was hampered as he didn't have his spikes for climbing as he'd lent them to a friend. So, he had to climb the traditional way using ropes which is a lot slower. But, he took a lot of care and got the plane down safely by lowering it on a rope. Peter offered Tony £60 for the rescue but he'd only take £40, something we don't expect these days. So, if you are unlucky enough to shove your plane in a tree, give him a ring on 07967 739722

Sorry, this is not actually the man that Peter called, I missed taking their photo.



We've not heard anything from Sita regarding our tenure at the field over the 'Summer'. We'll be contacting them soon to ask about staying at the field for as long as possible. As mentioned here before, the Government changed the timescales for grants for Solar Panel Farms in the last Budget. Consequently, the Grants are ending even sooner than the original 2017 deadline. All we can do is sit and keep fingers crossed that this is another nail in the coffin for the Harefield Solar panel farm.



A friend of mine was lucky enough to have a flight in the Caroline Grace Spitfire the other day. The plane started life as a Mk 9 Spitfire and claimed a kill on D Day. The plane was converted to a two seater in the 50's.

Today, you can have a flight for 20 minutes for £3,000, worth every penny! Mind you, he was on the waiting list for 7 years.

I was lucky enough to be invited along as a spectator.

The Nationals 2015

I went to the Nationals on the Saturday and enjoyed the sights. Here's a snap of the soon to be launched Tony Nijhuis Mosquito. It will be featured in the RCM & E Special that comes out in October. Chairman Mat had asked me to buy him a set of CNC cuts parts and the plan for his winter build. The plane is electric powered and sports near scale 3 bladed propellers. At 6' wingspan, it certainly looked impressive.



The Nationals are going on as I type but unless there is a marked divide in the weather, the Bank Holiday flying may well be a washout. If you've never been, it is worth a trip for the day. All the various disciplines are there, even if you're not interested, its worth a few minutes watching to see the various facets to our hobby. I'm fascinated by the Control Line racing, just to watch the men in the middle pirouetting around and round. The speed of these little planes is quite amazing too, some of their 'catch, refuel, restart and launch in under 2 seconds' was great to see.

The flight line for the big 'show' models was equally impressive, the standard of flying is extremely high.

I watched the Stand Off Scale competition and again, the standard was fantastic. Luckily, the brisk wind was straight down the runway which helped the competition..

Just as an aside, here's a snapshot I took of the mighty Vulcan and Red Arrows at the Fairford Airshow, another day when the sun did shine!



Club member Stevie from St Albans has imported a little project for himself, a 1933 Ford 3 window Coupe sporting a huge Chevrolet small block 5.7 litre V8 engine.

The car has been in a rust free environment for the last several decades and Steve has had it shipped over from the States, he intends to carry out some work on it himself to make it a bit safer to drive, like some decent brakes and better steering. He does intend to leave the original paintwork alone though.



Stevie is snapped here in his fancy dress outfit from Corfu.



Indoor Flying Friday 11th September 19.30-21.30

After our glorious Summer, you'll be pleased to know that some decent flying conditions that are guaranteed are returning. Indoor flying sessions return at Vyners School 1st Friday night each month. Always check the Club Website as School Holidays sometimes change the date. Pay on the night but as before, contributions are capped at £45 for the season.



Thursday 8th October Chuck Glider Competition at Battle of Britain Club.

A reminder to all that the above date is the Chuck Glider competition, look through your plans and commit your design to memory. We'll provide the balsa and plasticine nose weight, you provide your own glue, knives and first aid kit.

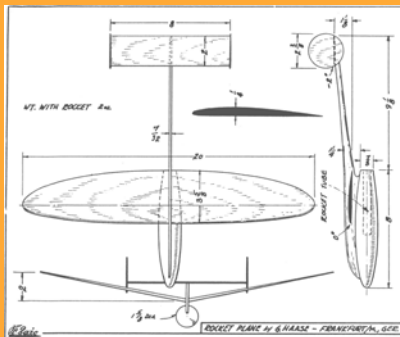

Club BBQ on Wednesday 9th September

We are hosting the last Club field BBQ for the year on the above date. As the nights are drawing in, get there earlier and have a fly before munching away on a burger or two. We'll provide all the food and soft drink so pop along and hopefully the weather will be good enough for a fly. We are also holding a Club Committee meeting straightaway afterwards so if there are any burning issues, tell any of the Committee and we'll give it an airing.

The Bloomin' Web Cam

The Web Cam has been mucking around again after a period of relatively reliable performance. I tried to improve the picture quality as a couple of people had said that it was a bit small and blurry. They're right, it is, the camera is not the best but it only cost £20. Anyway, I found a way to increase the picture size and set it going. I made sure that it was publishing the photos and then went home. By the time I'd reached home it had stopped. It redeemed itself by sparking into life the next day. However, because I'd increased the picture size, we now use more data and I'd exceeded the limit we pay for so it stopped again. I've returned the picture size to the smaller, blurry size but we'll have to wait to the next months quota of data before the pictures will be transmitted.